



US008646522B1

(12) **United States Patent**
Orgeron

(10) **Patent No.:** **US 8,646,522 B1**
(45) **Date of Patent:** ***Feb. 11, 2014**

(54) **METHOD OF GRIPPING A TUBULAR WITH A TUBULAR GRIPPING MECHANISM**

(75) Inventor: **Keith J. Orgeron**, Spring, TX (US)

(73) Assignee: **T&T Engineering Services, Inc.**, Tomball, TX (US)

(*) Notice: Subject to any disclaimer, the term of this patent is extended or adjusted under 35 U.S.C. 154(b) by 0 days.

This patent is subject to a terminal disclaimer.

2,124,154 A	7/1937	Sovincz	
2,147,002 A	2/1939	Volpin	
2,509,853 A *	5/1950	Wilson	166/77.51
2,535,054 A	12/1950	Ernst et al.	
2,814,396 A	11/1957	Neal, Sr.	
3,016,992 A	1/1962	Wilson	
3,059,905 A	10/1962	Tompkins	
3,177,944 A	4/1965	Knights	
3,194,313 A	7/1965	Fanshawe	
3,280,920 A	10/1966	Scott	
3,290,006 A	12/1966	Dubberke	
3,331,585 A	7/1967	Dubberke	

(Continued)

FOREIGN PATENT DOCUMENTS

(21) Appl. No.: **13/226,343**

JP	2001-287127 A	10/2001
WO	93/15303 A1	8/1993

(22) Filed: **Sep. 6, 2011**

OTHER PUBLICATIONS

Related U.S. Application Data

(63) Continuation of application No. 12/371,591, filed on Feb. 14, 2009, now Pat. No. 8,011,426, which is a continuation-in-part of application No. 12/359,926, filed on Jan. 26, 2009, now Pat. No. 8,474,806.

Chronis, Nicholas P.; Mechanisms & Mechanical Devices Sourcebook, 1991, Ch. 10, pp. 399-414, ISBN 0-07-010918-4, McGraw-Hill, Inc.

Primary Examiner — Daniel P Stephenson

Assistant Examiner — Catherine Loikith

(74) *Attorney, Agent, or Firm* — John G. Fischer, Esq.; Scheef & Stone, L.L.P.

(51) **Int. Cl.**
E21B 19/16 (2006.01)

(57) **ABSTRACT**

(52) **U.S. Cl.**
USPC **166/85.1**; 166/77.51; 414/739; 414/745.4

(58) **Field of Classification Search**
USPC 166/77.1, 77.51, 85.1; 294/102.2; 414/739, 740, 741, 745.4
See application file for complete search history.

A method for gripping a tubular with a tubular gripping mechanism includes the steps of moving the tubular gripping mechanism adjacent the tubular, positioning a jaw assembly of the tubular gripping mechanism around the tubular, applying a force by an actuator onto the jaw assembly of the tubular gripping mechanism such that the jaw assembly moves so as to clamp onto the tubular, removing the force from the actuator onto the jaw assembly such that the jaw assembly remains clamped onto the tubular. The clamping force is directed to surfaces of the tubular gripping mechanism away from the actuator.

(56) **References Cited**

U.S. PATENT DOCUMENTS

1,396,317 A *	11/1921	Boyter	294/102.2
1,417,490 A *	5/1922	Brandon	166/77.51
1,972,635 A *	9/1934	Whinnen	254/394
1,981,304 A *	11/1934	Brandt	188/67

17 Claims, 8 Drawing Sheets

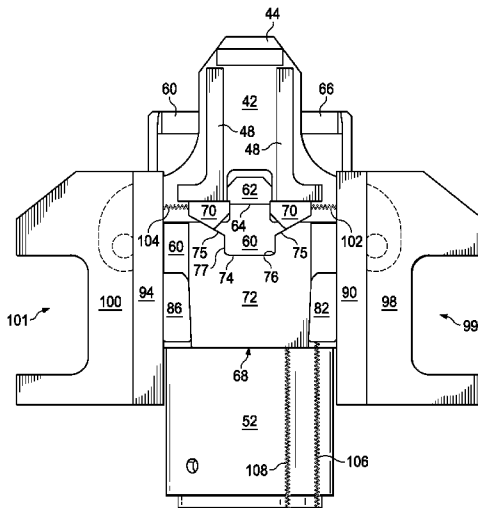

(56)

References Cited

U.S. PATENT DOCUMENTS

3,365,762 A	1/1968	Spiri	6,253,845 B1	7/2001	Belik	
3,432,159 A	3/1969	Rakatansky	6,263,763 B1	7/2001	Feigel, Jr. et al.	
3,561,811 A	2/1971	Turner, Jr.	6,279,662 B1	8/2001	Sonnier	
3,675,303 A	7/1972	McKinnon	6,311,788 B1 *	11/2001	Weixler	175/52
3,702,640 A *	11/1972	Cintract et al.	6,471,439 B2	10/2002	Allamon et al.	
3,703,968 A	11/1972	Uhrich et al.	6,543,551 B1	4/2003	Sparks et al.	
3,806,021 A	4/1974	Moroz et al.	6,543,555 B2	4/2003	Casagrande	
3,848,850 A	11/1974	Bemis	6,550,128 B1	4/2003	Lorenz	
3,883,009 A *	5/1975	Swoboda et al.	6,557,641 B2	5/2003	Sipos et al.	
3,986,619 A	10/1976	Woolslayer et al.	6,581,698 B1	6/2003	Dirks	
4,030,698 A	6/1977	Hansen	6,745,646 B1	6/2004	Pietras et al.	
4,221,269 A	9/1980	Hudson	6,748,823 B2	6/2004	Pietras	
4,269,554 A *	5/1981	Jackson	6,763,898 B1	7/2004	Roodenburg et al.	
4,276,918 A	7/1981	Sigouin	6,814,149 B2	11/2004	Liess et al.	
4,290,495 A	9/1981	Elliston	6,845,814 B2	1/2005	Mason et al.	
4,303,270 A	12/1981	Adair	7,017,450 B2 *	3/2006	Bangert	81/57.33
4,403,666 A	9/1983	Willis	7,028,585 B2	4/2006	Pietras et al.	
4,403,897 A	9/1983	Willis	7,036,202 B2	5/2006	Lorenz	
4,440,536 A	4/1984	Scaggs	7,055,594 B1	6/2006	Springett et al.	
4,547,110 A	10/1985	Davidson et al.	7,090,035 B2	8/2006	Lesko	
4,595,066 A	6/1986	Nelmark et al.	7,090,254 B1	8/2006	Pietras et al.	
4,650,237 A *	3/1987	Lessway	7,117,938 B2	10/2006	Hamilton et al.	
4,765,225 A	8/1988	Birchard	7,121,166 B2	10/2006	Drzewiecki	
4,834,604 A	5/1989	Brittain et al.	7,249,639 B2	7/2007	Belik	
4,869,137 A	9/1989	Slator	7,296,623 B2 *	11/2007	Koithan et al.	166/250.01
5,150,642 A	9/1992	Moody et al.	7,398,833 B2	7/2008	Ramey et al.	
5,458,454 A	10/1995	Sorokan	7,438,127 B2	10/2008	Lesko	
5,595,248 A	1/1997	Denny	7,503,394 B2	3/2009	Bouligny	
5,609,226 A	3/1997	Penisson	7,946,795 B2	5/2011	Orgeron	
5,649,745 A	7/1997	Anderson	8,011,426 B1 *	9/2011	Orgeron	166/85.1
5,660,087 A	8/1997	Rae	8,235,104 B1	8/2012	Sigmar et al.	
5,848,647 A	12/1998	Webre et al.	8,474,805 B2	7/2013	DeFranks et al.	
5,931,238 A	8/1999	Gilmore et al.	2002/0079105 A1	6/2002	Bergeron	
5,992,801 A	11/1999	Torres	2003/0221871 A1	12/2003	Hamilton et al.	
5,993,140 A	11/1999	Crippa	2005/0269133 A1	12/2005	Little	
6,047,771 A	4/2000	Roynestad	2006/0027793 A1	2/2006	Kysely	
6,220,807 B1	4/2001	Sorokan	2006/0278400 A1	12/2006	Bouligny	
6,227,587 B1 *	5/2001	Terral	2008/0078965 A1	4/2008	Lane et al.	
6,237,445 B1	5/2001	Wesch, Jr.	2008/0174131 A1 *	7/2008	Bouligny et al.	294/88
			2008/0202812 A1	8/2008	Childers et al.	
			2008/0253866 A1	10/2008	Lops et al.	

* cited by examiner

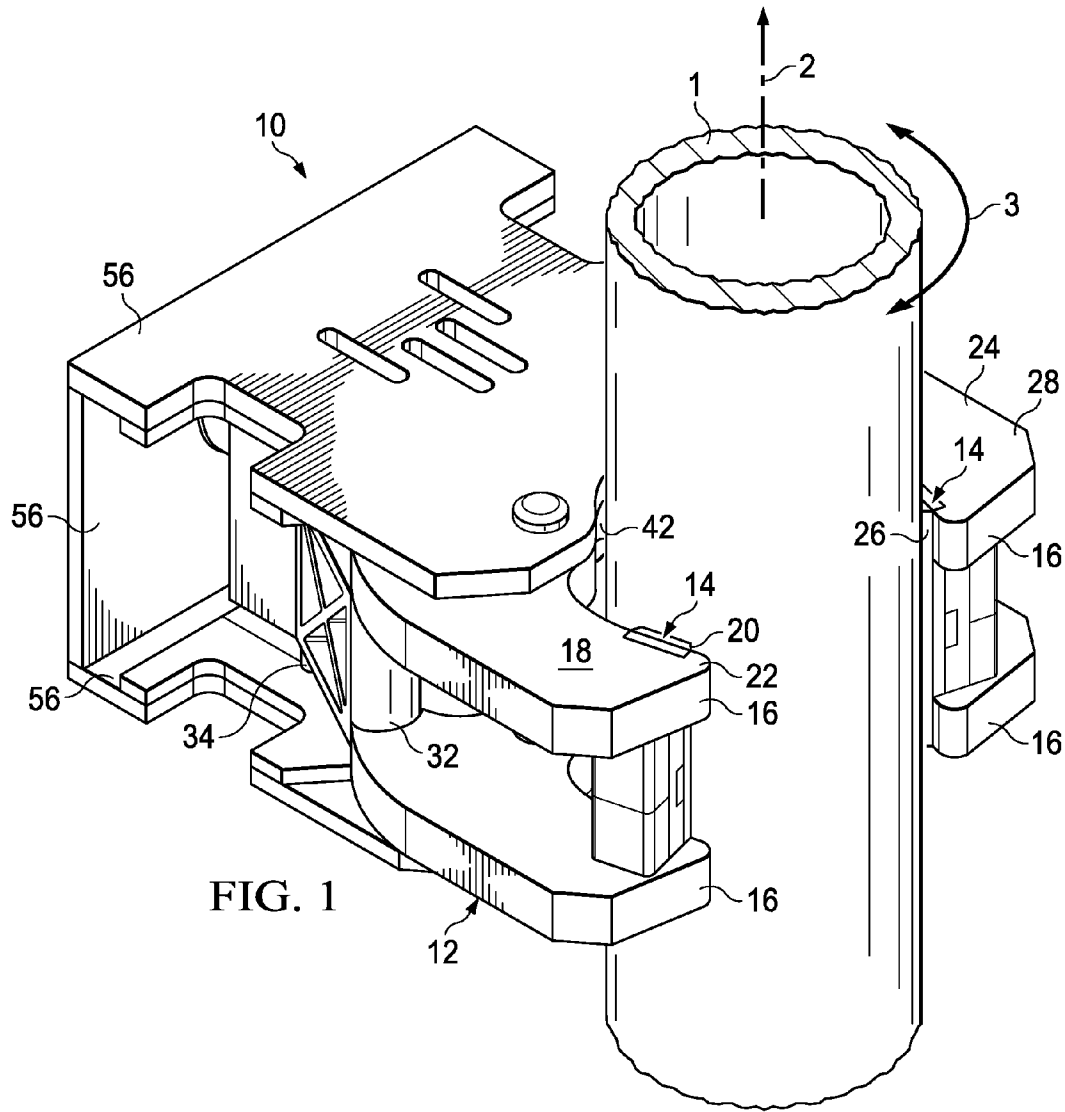

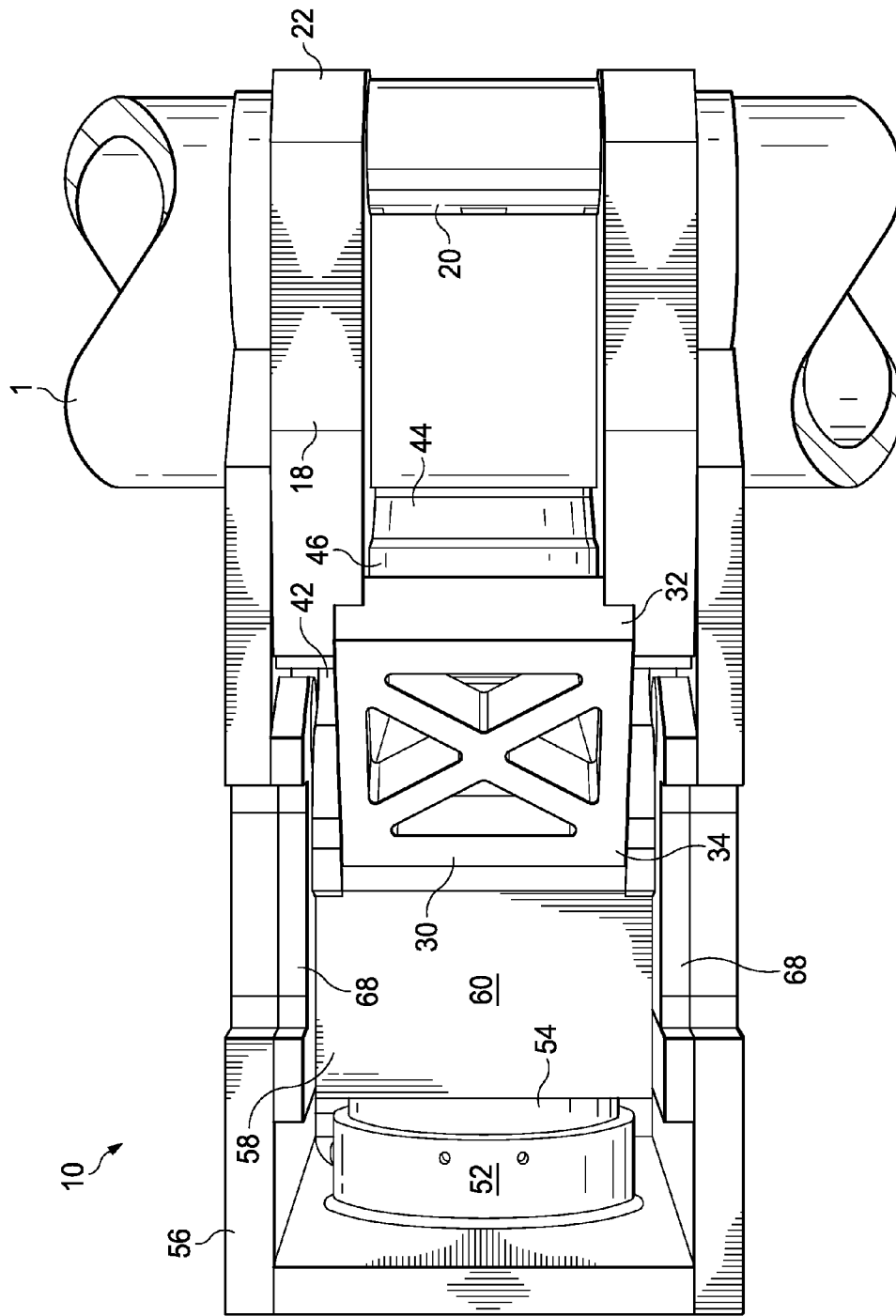

FIG. 2

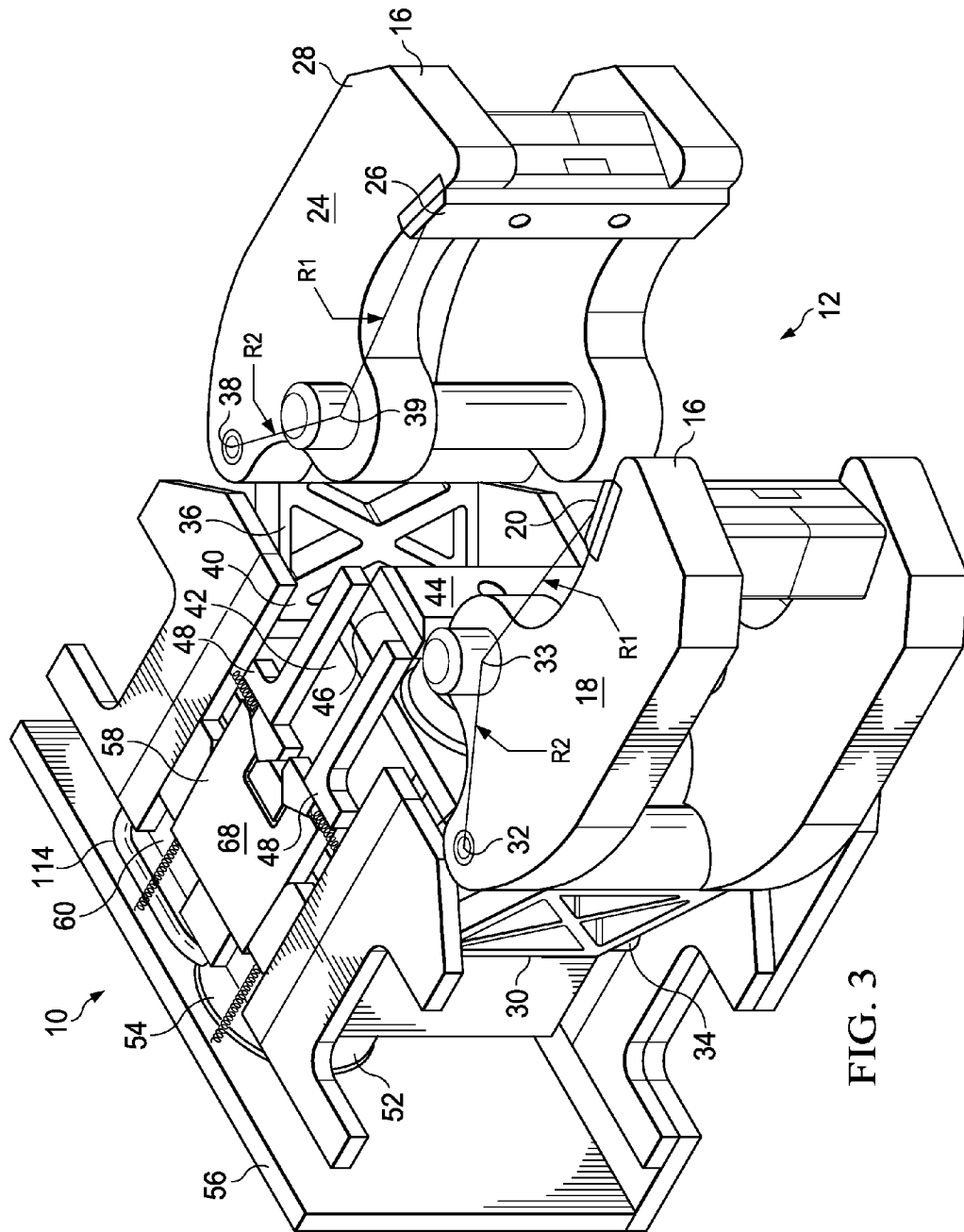

FIG. 3

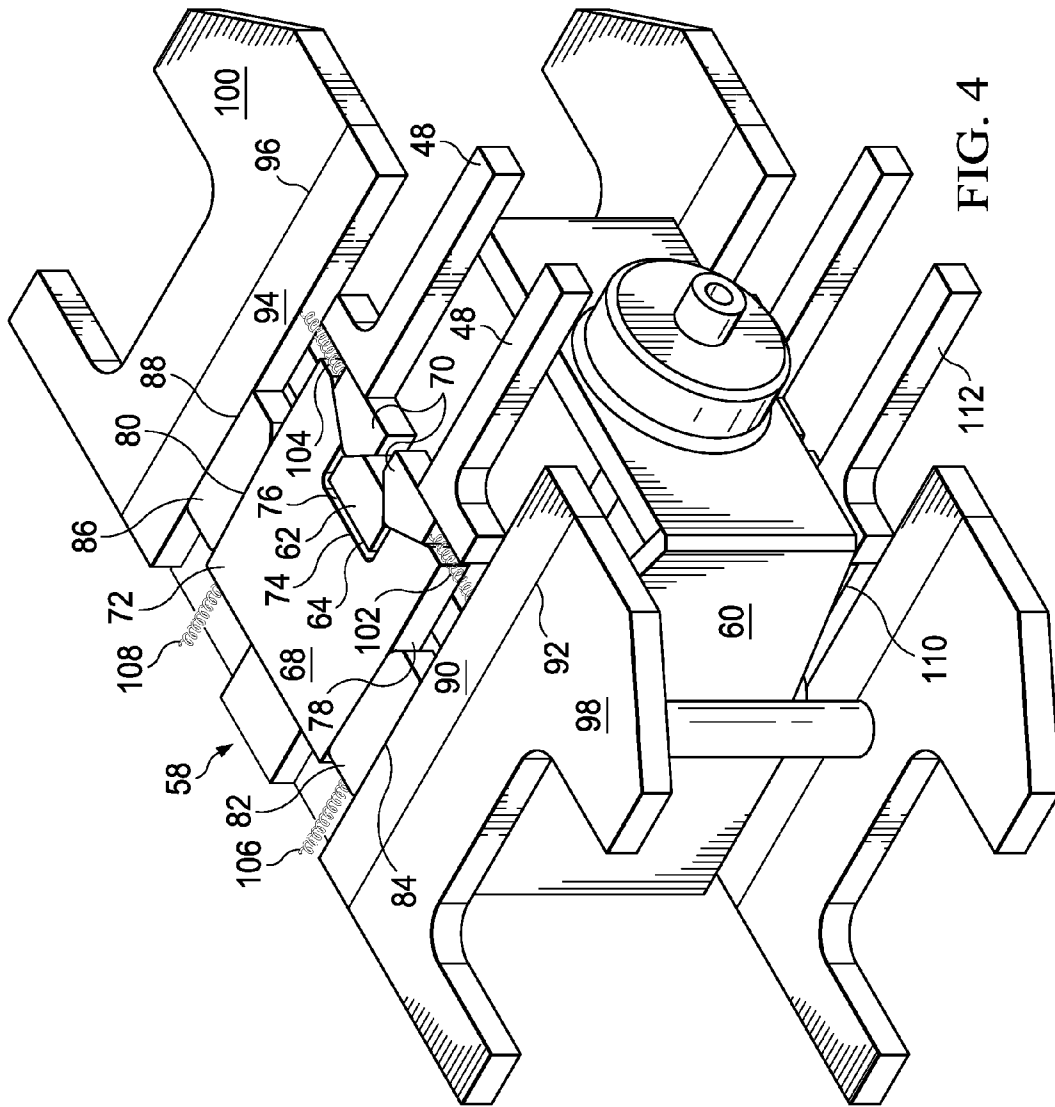

FIG. 4

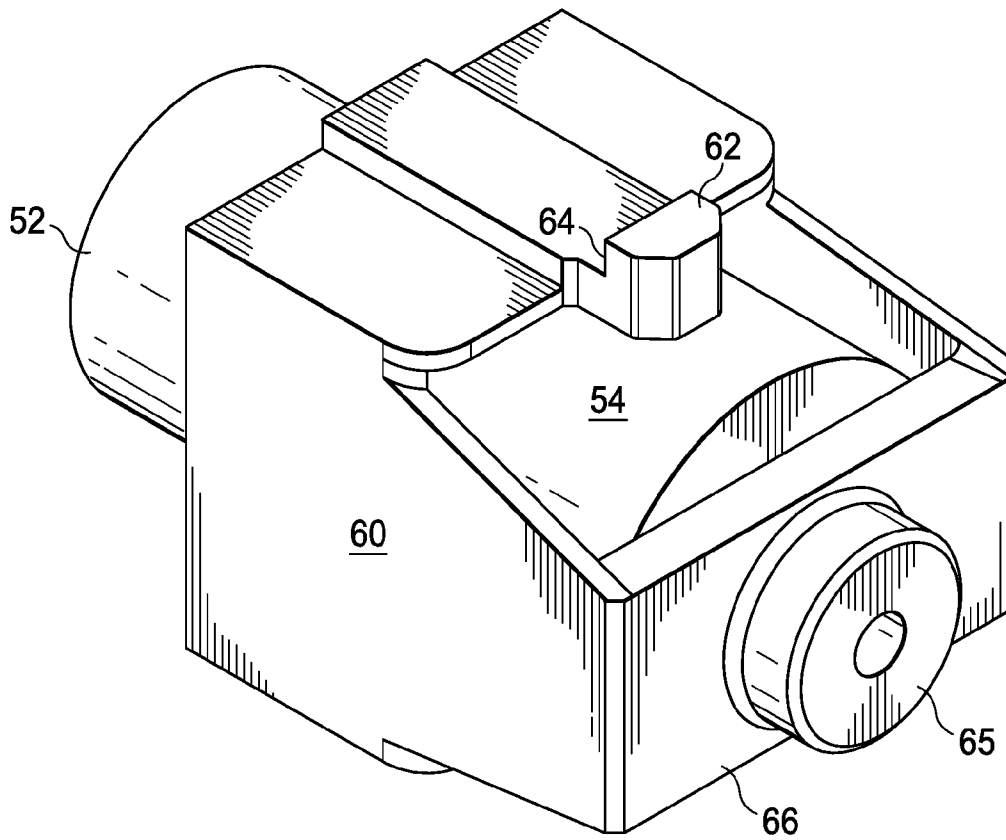
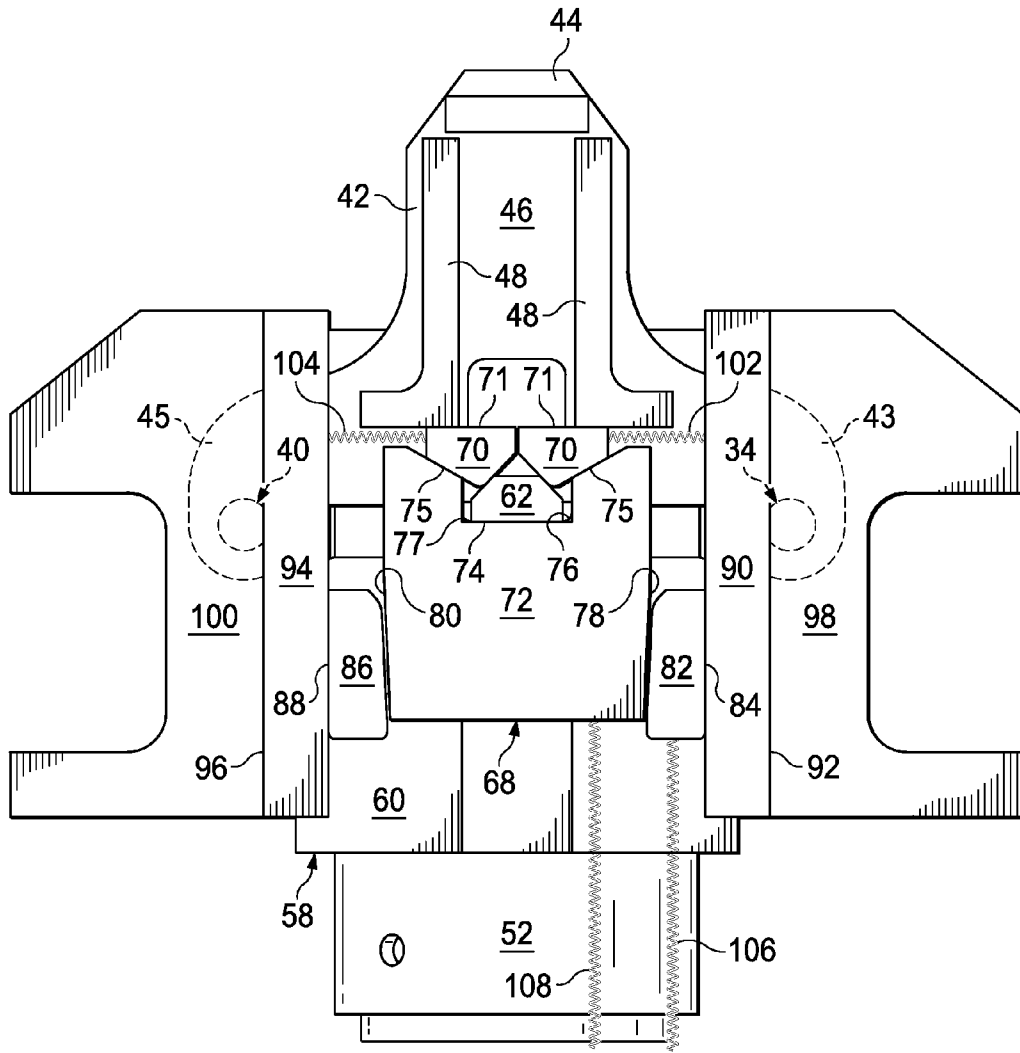

FIG. 5



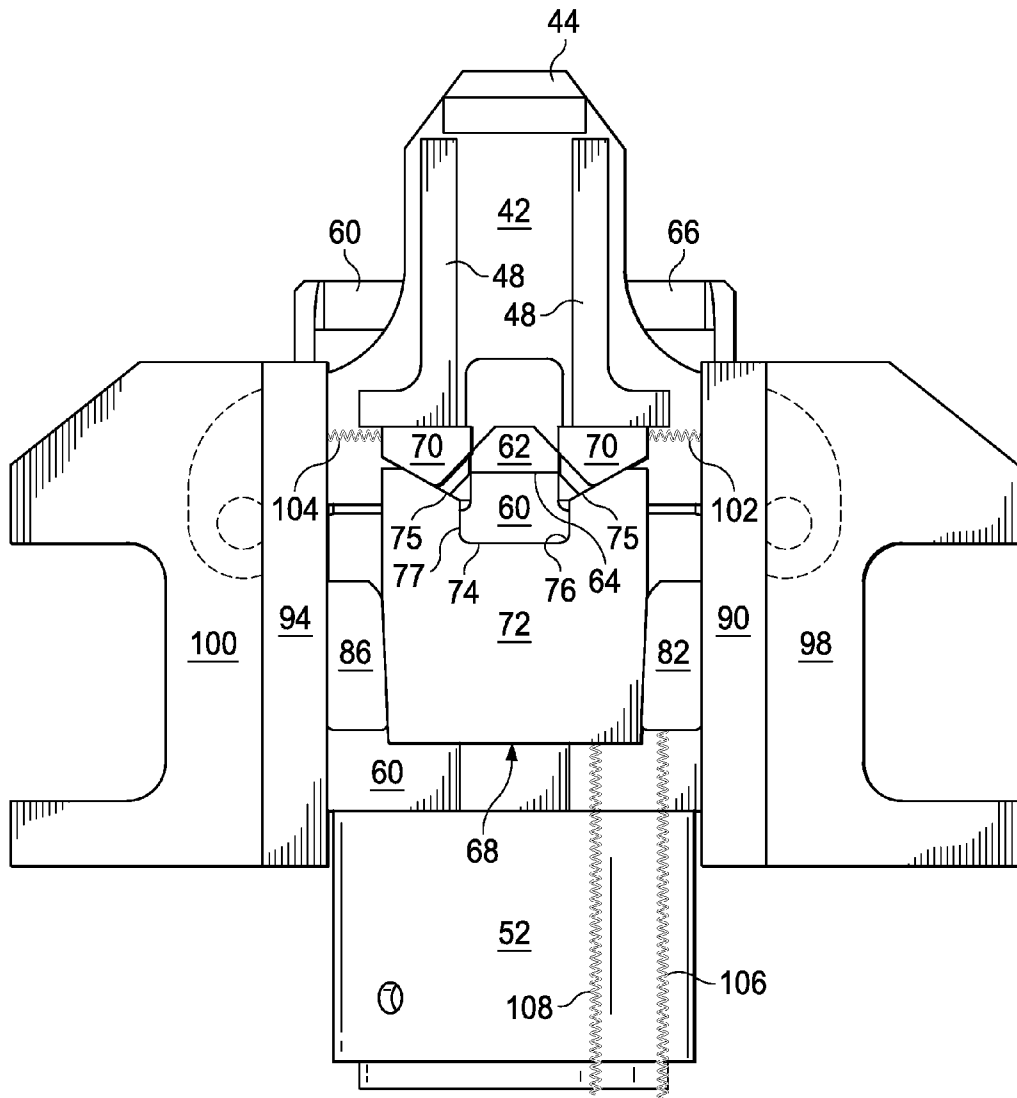

FIG. 7

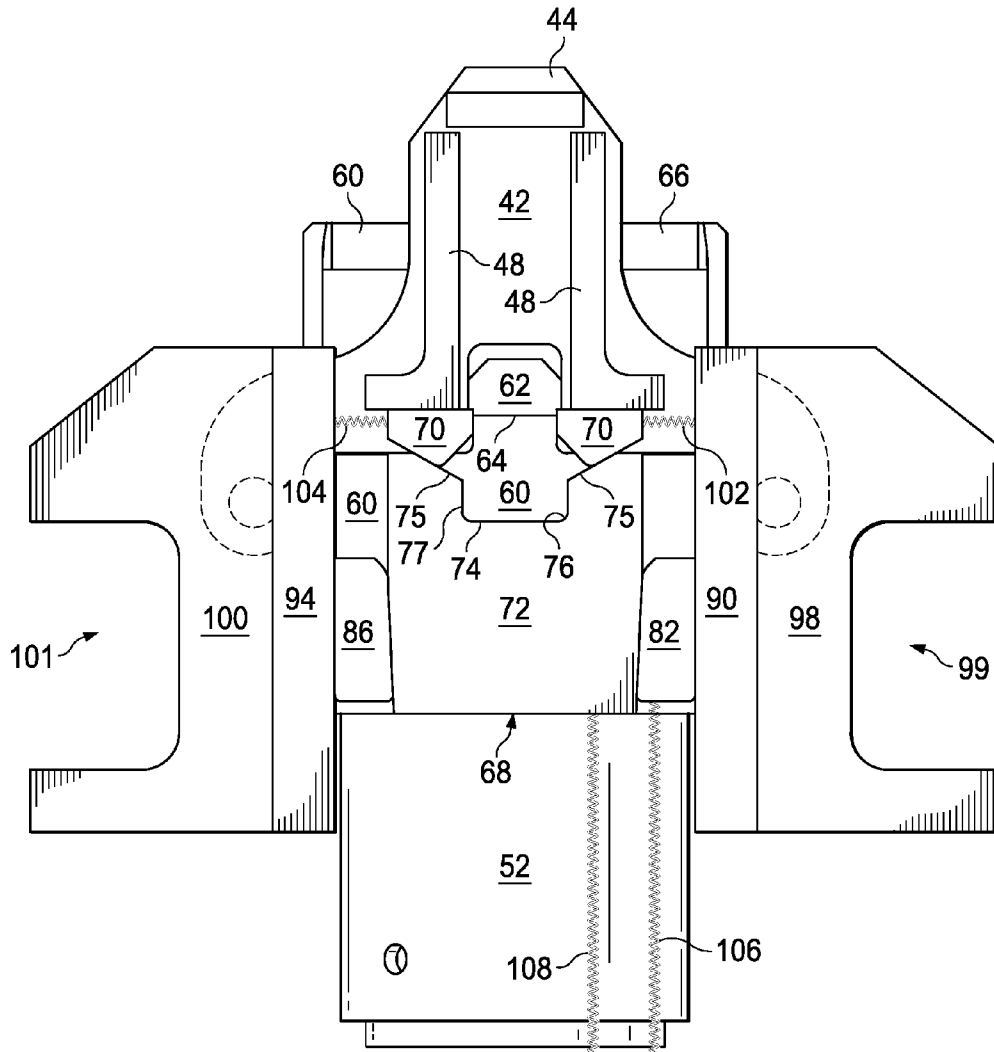

FIG. 8

1

METHOD OF GRIPPING A TUBULAR WITH A TUBULAR GRIPPING MECHANISM

CROSS-REFERENCE TO RELATED APPLICATIONS

The present application is a continuation-in-part of U.S. application Ser. No. 12/359,926, filed on 26 Jan. 2009, entitled "Pipe Gripping Apparatus," presently pending.

STATEMENT REGARDING FEDERALLY SPONSORED RESEARCH OR DEVELOPMENT

Not applicable.

NAMES OF THE PARTIES TO A JOINT RESEARCH AGREEMENT

Not applicable.

INCORPORATION-BY-REFERENCE OF MATERIALS SUBMITTED ON A COMPACT DISC

Not applicable.

BACKGROUND OF THE INVENTION

1. Field of the Invention

The present invention relates to a tubular gripping apparatus. More particularly, the present invention relates to a tubular gripping apparatus that can be used to grip different diameters of tubular. More particularly, the present invention relates to the diversion of a load associated with gripping a tubular. Additionally, the present invention relates to a tubular gripping apparatus whereby the tubular is properly centered regardless of the diameter of the tubular.

2. Description of Related Art Including Information Disclosed Under 37 CFR 1.97 and 37 CFR 1.98.

The term "tubular" as used herein includes all forms of drill tubulars, drill collars, pipe, casing, liners, bottom hole assemblies (BHA), and other types of tubulars known in the art. In well drilling and well completion operations, it is necessary to lift and properly align lengths of downhole tubulars. For example, in oil or water well drilling, multiple lengths of drill pipe must often be raised from a horizontal position at or near ground level to a vertical position aligned with the centerline of the well. Such lifting and aligning operations require clamps for securely holding the pipe in place as it is lifted. When a pivotally mounted pipe boom is used, this boom must support large loads in several different orientations.

Compounding this problem is the fact that each joint of a length of a down-hole tubular must be closely aligned with a string of such tubulars after it has been lifted to the vertical position, such as when a drill pipe or casing is made up. A clamp, or gripper, for this purpose should preferably provide a necessary alignment for down-hole tubulars having various diameters, without any adjustment. Proper alignment has been a problem with many such clamps, or grippers, of the prior art, especially those employing pivoted clamping jaws. When pivoted clamping jaws are used, there is a tendency for the center of the down-hole tubular to vary as a function of the diameter of the tubular being clamped.

U.S. patent application Ser. Nos. 11/923,451, filed on Oct. 24, 2007 and 12/013,979, filed on Jan. 14, 2008 by the present inventor, describe pipe handling apparatuses whereby pipe is moved from a horizontal position to a vertical position with a

2

single degree of freedom. In particular, these devices include grippers that grasp the pipe when it is in a horizontal position, move the pipe through the interior of a frame through the use of a particular pipe handling structure, and then position the pipe directly over the well center. Through the use of this device, pipe is accurately moved without the need for adjustment actuators or other mechanisms in order to provide the proper end location for the pipe. Unfortunately, with this device, the grippers associated with the device must be changed, as necessary, so as to accommodate the particular diameter of the pipe being used. The formation of such separate grippers is somewhat difficult because the grippers must be able to properly center the pipe. As such, a need has developed to provide a pipe gripper assembly whereby various diameters of pipe can be accommodated with a single gripper assembly and whereby the pipes that are accommodated by this gripper assembly are properly centered therein.

In many circumstances, the pipe can have very rigid side walls. In other circumstances, such as installation of a casing, the side walls of the tubular are relatively thin and flexible. As such, there is a need to develop a pipe gripper assembly whereby the various thicknesses of side walls can be accommodated by the tubular gripping mechanism. It is important that the tubular gripping mechanism not bend, deform, puncture or otherwise dent thin-walled tubulars.

In the past, various patents have issued relating to a tubular gripping mechanism. U.S. Pat. No. 3,280,920 issued on Oct. 25, 1966 to P. Scott, teaches a portable apparatus for drilling down hole wells. This apparatus has a mast having an open side and a means for supporting a string of drill pipes rotated within the mast. A means for raising and lowering a string of drill pipes in a rectilinear direction parallel to the longitudinal centerline of the mast is provided. This apparatus includes a hydraulic cylinder connected through a suitable arrangement of lines and sheaves so as to apply positive force upon the power swivel so as to move the swivel upwardly or downwardly in the mast as desired. This swivel is mounted on a wheeled carriage which runs on suitable tracks carried by the mast. An elongate frame is pivotably attached to the lower end of the mast for swinging movement to an open side of the mast between a substantially horizontal position and an upright position. Releasable clamps are adapted to grip a section of drill pipe mounted on the frame for a limited longitudinal reciprocating motion thereon.

U.S. Pat. No. 3,365,762, issued on Jan. 30, 1968 to W. H. Spiri, shows a well pipe gripping structure having a slip body having a pipe gripping insert which is slidably movable horizontally into an arcuate guideway in the slip body. The slip body is retained within the guideway by upper and lower lips on the body. The lips have asymmetric retaining surfaces. The inserts are provided with teeth which advance vertically as the teeth advance circularly. The teeth of one insert are positioned out of alignment with the teeth of the other insert to increase the resistance to rotation of the pipe within the slip structure.

U.S. Pat. No. 3,561,811, issued on Feb. 9, 1971 to J. W. Turner, Jr., teaches a well drilling rig having a pipe racker apparatus in which a number of racker arms are controllable from a remote location to engage drill pipe tool joints and drill collars. One of the arms has a head for supporting the weight of lengths of pipe or drill collars being added to or removed from the drill string.

U.S. Pat. No. 3,702,640, issued on Nov. 14, 1972 to Cin-track et al., shows a tipping girder with a transfer of tubular elements. This tipping girder has a plurality of adjustable guide nippers movably positioned on the girder for movement transverse to the longitudinal axis thereof. There are adjustable locking nippers movably mounted on the girder for

movement parallel to and transverse to the longitudinal axis thereof. The locking nippers are constructed to automatically engage and lock a rod on the girder when it is moved away from the horizontal position.

U.S. Pat. No. 3,806,21, issued on Apr. 23, 1974 to Moroz et al., shows a pipe centering apparatus. This apparatus has a carriage with a column mounted thereon to support a pipe end jointing mechanism. The carriage has a receptacle together with the column. The column pivotally supports a cantilever member of which the free extremity pivotably supports the pipe end jointing mechanism including coaxially arranged grippers adapted to retain the ends of the pipe.

U.S. Pat. No. 4,303,270, issued on Dec. 1, 1981 to H. L. Adair, shows a self-centering clamp for down-hole tubulars. This clamp includes first and second opposed clamping members guided along a clamping axis by first and second guide channels defined by a frame. Each clamping member defines a hydraulic cylinder in which is disposed a piston which is rigidly mounted to the frame. A rack is coupled to move with each of the clamping members. These racks are interconnected via a pinion gear which meshes with both racks so that the two clamping members move in a counter-directional manner and remain equidistant from a central point on the clamping axis.

U.S. Pat. No. 4,403,897, issued on Sep. 13, 1983 to Willis, provides self-centering clamp for drilling tubulars. This self-centering clamp includes first and second transverse guide rods. Two opposed clamping jaws are guided along the first guide rod. These jaws are positioned by two opposed rocker arms, each of which is mounted to a cross brace which slides along the second guide rod. The rocker arms are symmetrically positioned by a link mechanism which also slides along the second guide rod and by a hydraulic cylinder coupled between the two rocker arms. The frame is pivotably mounted to a pipe boom so as to rotate about an axis parallel to the clamped pipe and transverse to the first and second guide rods.

U.S. Pat. No. 4,650,237 issued on Mar. 17, 1987 to R. J. Lessway, provides an automatic centering and gripping apparatus which includes a housing in which is slidably mounted on a longitudinal movable operator body. A pair of gripper arms are slidably mounted on the operator body. Each gripper arm carries a gripper member engageable with a workpiece. The gripper members are moved longitudinally and laterally into gripping engagement with a workpiece when the operator body is moved in one longitudinal direction. They are correspondingly disengaged from the workpiece when the operator body is moved in the other longitudinal direction.

U.S. Pat. No. 5,609,226 issued on Mar. 11, 1997 to V. J. Penisson, teaches a slip-type gripping assembly having an outer body defining a longitudinal through opening for receipt of the object. A number of slip bodies are circumferentially spaced about the through opening and are radially movable toward and away from the locus of the object. Each slip body is pivotable about a generally longitudinal axis and generally circumferentially centered with respect to the slip body as well as about a tangential axis. A respective force transfer formation is cooperative between each slip body and the outer body for transferring radial force therebetween while permitting the pivoting.

U.S. Pat. No. 5,848,647, issued on Dec. 15, 1998 to Webre et al., shows a pipe gripping apparatus for angularly adapting two misaligned pipe on one or more pipe strings. The apparatus has a housing having internal, opposing downwardly-curved surfaces therein and forming a longitudinal opening for passing a portion of at least one tubing string there-through. A plurality of slip carriers each has an exterior sur-

face contoured to match the downwardly curved surface and has a downwardly inclined interior surface. Each slip carrier is in movable connection with one of the curved surfaces of the housing. A plurality of slips have downwardly inclined exterior surfaces and longitudinal channels formed on an internal surface for holding gripping elements for gripping a portion of the pipe

U.S. Pat. No. 5,992,801, issued on Nov. 30, 1999 to C. A. Torres, discloses a pipe gripping assembly and method. This pipe gripping assembly has primary pipe gripping mechanism and a backup and a secondary pipe gripping mechanism carried in a single tapered slip bowl. The primary gripping mechanism employs smooth surface pipe dies that set against and grip and hold the pipe without damaging the pipe surface. After the primary mechanism is set, toothed dies in the secondary gripping mechanism are automatically engaged with the pipe with only a minimal pipe gripping force. Additional slippage of the pipe through the smooth dies sets the toothed dies down against a wedging surface to grip and hold the pipe to stop its downward movement. A resilient biasing device is used to urge the toothed dies away from the pipe before the smooth dies are set.

U.S. Pat. No. 5,993,140, issued on Nov. 30, 1999 to A. Crippa, shows an apparatus for loading pipes onto processing machines. This apparatus has a handler arm with a first segment and a second segment disposed in succession. Kinematic members are adapted to define a fixed ratio between the rotation angles of the segments about the respective hinging axes.

U.S. Pat. No. 6,543,551, issued Apr. 8, 2003 to Sparks et al., discloses an automatic pipe handling device which includes a support frame mounted on a boring device. Removable pipe racks can be placed in position on the support frame to deliver pipe to the spindle axis or to remove pipe therefrom as required. The pipe sections are removed from the pipe rack and positioned on the spindle axis by pipe grippers mounted on hydraulic cylinders mounted on a rotating longitudinal shaft. The grippers and shaft simultaneously return the used pipe sections for storage to the pipe rack.

U.S. Pat. No. 6,543,555, issued on Apr. 8, 2003 to M. Casagrande, provides an automatic loader for drill rods adapted to be used in association with a boring machine. The automatic motor has a store containing a plurality of drill rods and a movement assembly that is able to selectively remove, one at a time, the drill rods from the store to position them on the guide and drive assembly. The movement assembly is arranged in an intermediate position between the store and the guide and drive assembly so as to not interfere with the latter during the removal of the drill rods from the store.

U.S. Pat. No. 6,845,814, issued on Jan. 25, 2005 to Masson et al., teaches a pipe-gripping structure having load rings. In particular, a rotary slip supports a drill string having a plurality of slip segments connected to define an opening for insertion of the drill string. Each slip segment has a head region, a toe region, and an inner radial surface axially extending between the head and toe regions. The inner radial surface of each slip segment comprises a circumferential groove. A plurality of axially aligned drill string gripping inserts are attached to each slip segment between the head region and the circumferential groove. Each insert has a gripping surface for contacting the drill string.

U.S. Pat. No. 7,055,594, issued on Jun. 6, 2006 to Springett et al., describes a pipe gripper and top drive system in which the pipe gripping system is located beneath the top drive unit. The pipe gripping system has an open throat for receiving a tubular to be gripped by the pipe gripping system. The gripping system has a body with first and second jaws movably

connected thereto and a piston/cylinder assembly movably interconnected with each jaw for moving the jaws to clamp and then to rotate the pipe.

U.S. Pat. No. 7,090,035, issued on Aug. 15, 2006 to G. Lesko, describes a method and system for connecting pipe to a top drive motor. This system includes a top drive motor that tilts about a horizontal axis and a pipe launcher that brings joints of pipe up to the drilling platform for connection with a top drive motor at a safe and convenient height above the platform. The top drive motor further includes a clamping assembly that grasps and pulls the joint of the pipe to the motor as the connection is being made. The clamp assembly supports the motor-pipe connection as the top-drive motor is raised in the drilling mast of the rig bringing the joint of pipe up into a vertical orientation for connection with the drill tubing string.

U.S. Pat. No. 7,121,166 B2, issued on Oct. 17, 2006 to Drzewiecki, discloses a tong assembly that has a body and a center member slidable relative to the body. A pair of clamping arms are rotatably connected to the body. The clamping arms are connected to the center member such that as the center member slides relative to said body, the clamping arms rotate relative to the body. The assembly also comprises a plurality of die assemblies, wherein at least one die assembly is mounted to each clamping arm and at least one die assembly is mounted to the center member.

U.S. patent application Ser. No. 12/111,907, filed on Apr. 29, 2008 by the present inventor, discloses a pipe gripping apparatus that has a first jaw with a pipe-contacting surface at one end thereof, a second jaw having a pipe-contacting surface at one end thereof, a tongue having a pipe-contacting surface at one end thereof, and an actuator connected to the first and second jaws and to the tongue. The actuator serves to move the first and second jaws and the tongue such that the pipe-contacting surfaces thereof move radially inwardly simultaneously for a substantially identical distance. A first link pivotally connects the tongue with the first jaw. A second link pivotally connects the tongue with the second jaw. The first and second links extend angularly outwardly from the tongue. The first and second pivot points of each jaw have a distance unequal to a distance between the first pivot point and pipe-contacting surface of each jaw. The pipe-contacting surfaces can be elastomeric pads, toothed dies, or rollers.

A problem associated with using the pipe gripping apparatus disclosed in U.S. patent application Ser. No. 12/111,907 is that a large load is imparted onto the outer surface of the pipe by the jaws of the apparatus. The large load is sustained by the actuator of the apparatus; however, the piston and cylinder of the actuator can prematurely fail due to constant application of the load of gripping to the pipe. Thus, there is a need for a gripping mechanism that reduces the load on the piston and cylinder of the actuator so as to increase the useful life thereof and avoid early fatigue and failure.

Various patents have issued relating the loads exerted by gripping mechanism. For example, U.S. Pat. No. 6,279,662, issued on Aug. 28, 2001 to Sonnier, discloses a conventional center-latch elevator with smooth slip segments of the present invention is employed to grip and suspend a pipe without damaging the pipe surface. The slip segments are made of aluminum or another material that is softer than the material of the pipe. The elimination of rough surfaces on the slip segments prevents damage to the external pipe surface. A threaded lift connector is secured to the box end of the pipe to be lifted. The lift connector forces spring-loaded slip segments down into the conical bowl of the elevator to move the segments radially inwardly into gripping engagement with the pipe. The axial forces exerted by the elevator against the

bottom of the lift connector are transmitted through the connector to the threads engaged in the pipe.

U.S. Pat. No. 4,869,137, issued on Sep. 26, 1989 to Stator, discloses an improved jaw construction for power tongs and bucking units wherein the jaws include a pair of gripping pads which are mounted to the jaws with a resilient insert so that loads applied through the jaw to the pipe are distributed over the gripping pads to minimize scoring the pipe or deformation thereof.

It is an object of the present invention to remove the hydraulic cylinder of the actuator of a gripping mechanism from a load path.

It is another object of the present invention to increase the useful life of the actuator of a gripping mechanism.

It is another object of the present invention to lock the gripping mechanism around a tubular in the event of a loss of power to the gripping mechanism.

It is still another object of the present invention to use the gripping power of a gripping mechanism for other purposes, such as rotating tubulars, while the gripping mechanism holds a tubular.

It is another object of the present invention to provide a tubular gripping mechanism that can be used as a tong.

It is another object of the present invention to provide a tubular gripping mechanism whereby different diameters of tubular can be gripped by the same mechanism.

It is still another object of the present invention to provide a tubular gripping mechanism which self-centers the tubulars regardless of the diameter of the tubular.

It is another object of the present invention to provide a tubular gripping mechanism which includes a locking mechanism so as to prevent unintended release of the tubular.

It is still another object of the present invention to provide a tubular gripping mechanism that can be used in conjunction with a tubular handling device.

It is another object of the present invention to provide an mechanism to grip and to center any shape having three surfaces with the same radius to the center of the shape.

It is another object of the present invention to provide an mechanism to grip and to center any shape, having a means for variable locking of the shape.

It is still another object of the present invention to provide an mechanism to grip and to center any shape, clamping with a greater force than the actuator.

It is another object of the present invention to provide an mechanism to grip with zero centering error for any two tubular diameters.

It is another object of the present invention to use three points of contact for gripping a tubular.

It is another object of the present invention to have an infinitely variable brake position.

It is another object of the present invention to multiply the gripping force of the gripping mechanism so as to enhance the load delivered by the cylinder of the actuator.

It is another object of the present invention to lock the jaws of a gripping mechanism around a tubular.

It is still another object of the present invention to avoid elastic and plastic deformation of a tubular while gripping.

It is another object of the present invention to distribute the contact pressure of the gripper mechanism over the surface of the tubular.

It is another object of the present invention to provide a tubular gripping mechanism with a single actuator with a single degree of freedom.

It is another object of the present invention to move the tubular to the gripper.

These and other objects and advantages of the present invention will become apparent from a reading of the attached specification and appended claims.

BRIEF SUMMARY OF THE INVENTION

The present invention is a method for gripping a tubular with a tubular gripping mechanism. The method includes the steps of moving the tubular gripping mechanism adjacent the tubular, positioning a jaw assembly of the tubular gripping mechanism around the tubular, applying a force by an actuator onto the jaw assembly of the tubular gripping mechanism such that the jaw assembly moves so as to clamp onto the tubular, removing the force from the actuator onto the jaw assembly such that the jaw assembly remains clamped onto the tubular, and rotating the tubular about a longitudinal axis thereof when the force of the actuator is removed.

The tubular gripping mechanism has a drive yoke with a tubular-contacting surface at an end thereof. The drive yoke is cooperative with the jaw assembly. The step of applying a force includes applying a force by the actuator onto the drive yoke so as to urge the drive yoke outwardly into contact with the tubular. The step of applying a force further includes driving the drive yoke and moving the jaw assembly such that the tubular-contacting surfaces thereof move radially inwardly for a substantially identical distance.

The tubular gripping mechanism having a locking mechanism therein. The method further includes engaging the jaw assembly with the locking mechanism such that the force of clamping is passed to the locking mechanism.

The drive yoke has a bearing bar thereon. The locking mechanism has a cylinder yoke with a nose positioned adjacent the drive yoke and a wedge assembly positioned adjacent the bearing bars. The step of removing a force includes contacting the wedge assembly with the cylinder yoke so as to fix a position of the cylinder yoke, passing the nose of the cylinder yoke through the wedge assembly, orienting the wedge assembly so that the nose of the cylinder yoke is outside the wedge assembly, preventing the nose of the cylinder yoke from moving interior of the wedge assembly, and transmitting the load from the drive yoke to the wedge assembly.

The actuator is a piston-and-cylinder assembly cooperative with the jaw assembly. The step of removing a force includes retracting the piston-and-cylinder assembly away from the tubular so that a force of clamping is directed away from the piston-and-cylinder assembly.

The wedge assembly comprises a pair of clamping wedges positioned adjacent the bearing bar, the pair of clamping wedges positioned adjacent the nose of the cylinder yoke, a braking plate having an end adjacent the pair of clamping wedges and having an indentation formed in the end, a first braking wedge positioned adjacent a side of the braking plate, a second braking wedge positioned adjacent an opposite side of the braking plate, a first brake pad positioned adjacent a side of the first braking wedge opposite the braking plate, a second brake pad positioned adjacent a side of the second braking wedge opposite the braking plate, a first brake shoe positioned adjacent a side of the first brake pad opposite the first braking wedge, and a second brake shoe positioned adjacent a side of the second brake pad opposite the second braking wedge.

The step of passing the nose includes traveling the nose between the pair of clamping wedges from the indentation of the braking plate to a side of the pair of clamping wedges. The step of orienting the wedge assembly includes pushing the pair of clamping wedges together, urging the braking plate toward the drive yoke, and urging the first braking wedge

toward the drive yoke. The step of preventing the nose includes contacting the pair of clamping wedges with a detent formed in the nose.

The step of transmitting the load from the drive yoke to the wedge assembly includes passing the load from the bearing bar of the drive yoke to the pair of clamping wedges, passing the load from the pair of clamping wedges to the braking plate, passing the load from the braking plate to the first and second braking wedges, passing the load from the first and second braking wedges to the first and second brake pads, and passing the load from the first and second brake pads to the first and second brake shoes. The step of passing the load from the pair of clamping wedges to the braking plate includes contacting the pair of clamping wedges with an angled portion of the indentation of the braking plate. The step of passing the load from the braking plate to the first and second braking wedges includes contacting the side of the braking plate with the first braking wedge, and contacting the opposite side of the braking plate with the second braking wedge. The step of passing the load from the first and second braking wedges to the first and second brake pads includes contacting the first brake pad with the side of the first braking wedge, and contacting the second brake pad with the side of the second braking wedge. The step of passing the load from the first and second brake pads to the first and second brake shoes includes contacting the first brake shoe with the side of the first brake pad, and contacting the second brake shoe with the side of the second brake pad.

BRIEF DESCRIPTION OF THE SEVERAL VIEWS OF THE DRAWINGS

FIG. 1 shows a perspective view of the tubular gripping mechanism used in the preferred method of the present invention.

FIG. 2 shows a side elevational view of the tubular gripping mechanism used in the method of the present invention.

FIG. 3 shows an upper perspective view of the tubular gripping mechanism used in the method of the present invention, with the top of the housing removed.

FIG. 4 is an isolated perspective view of the locking means of the tubular gripping mechanism used in the method of the present invention.

FIG. 5 is an isolated perspective view of the actuator means and cylinder yoke of the tubular gripping mechanism of the present invention.

FIG. 6 is an isolated plan view of the locking means in the first position.

FIG. 7 is an isolated plan view of the locking means in an intermediate position.

FIG. 8 is an isolated plan view of the locking means in the second position.

DETAILED DESCRIPTION OF THE INVENTION

Referring to FIG. 1, there is shown a perspective view of the tubular gripping mechanism 10 used in the preferred method of the present invention. The mechanism is shown in the second position. In the second position, the mechanism 10 grips and clamps tubular 1. As can be seen in FIG. 1, the tubular gripping mechanism 10 has a jaw assembly 12 positioned around the outer surface of the tubular 1. The jaw assembly 12 has tubular gripping surfaces 14 on the end 16 thereof. The tubular gripping surfaces 14 contact the tubular 1 when the mechanism 10 is in the second position. The tubular gripping mechanism 10 has a housing 56. The housing 56 covers the top, back, and bottom of the mechanism 10. The

jaw assembly 12 has a portion that moves within the housing 56. The unique configuration of the jaw assembly 12 allows the mechanism 10 of the present invention to grip large and small diameters of tubulars without having to change the jaws of the jaw assembly 12. Thus, the mechanism 10 of the present invention eliminates the need for additional adapters and thus removes the associated costs from gripping tubulars 1.

The jaw assembly 12 has a first jaw 18 and a second jaw 24. The first jaw 18 has a pipe-contacting surface 20 at one end 28 thereof. The second jaw 24 has a pipe-contacting surface 26 at one end 28 thereof. The first and second jaws 18 and 24 are connected to a drive yoke 42. A first link 30 is connected to the first jaw 18 and the drive yoke 42. The first link 30 is pivotally connected at a first pivot point 32 to the first jaw 18. The first link 30 is pivotally connected at a second pivot point 34 to the drive yoke 42. A second link 36 is connected to the second jaw 24 and to the drive yoke 42. The second link 36 is connected at a first pivot point 38 to the second jaw 24. The second link 36 is pivotally connected at a second pivot point 40 to the drive yoke 42. An elastomeric pad is the pipe-contacting surface 20 of the first jaw 18. As such, the pipe-contacting surface 20 is slightly flexible so as to avoid any damage to the outer surface of the tubular 1. An elastomeric pad is the pipe-contacting surface 26 of the second jaw 24. The links 30 and 36 assure that there is a proper movement of the jaws 18 and 24 radially inwardly relative to the movement of the drive yoke 42. The links 30 and 36 are anchored to housing 56. In FIG. 1, the longitudinal axis 2 of the tubular 1 can be seen. The gripping mechanism 10 can rotate the tubular 1 about the longitudinal axis 2 thereof, as is shown by the arrow 3 of rotation in FIG. 1.

Referring to FIG. 2, there is shown a side elevational view of the tubular gripping apparatus 10 in the second position. The apparatus 10 holds the tubular 1 when in the second position. The first link 30 can be seen attached to the first jaw 18 of the jaw assembly 12. The apparatus 10 has a drive yoke 42. The drive yoke 42 also has a tubular-contacting surface 44 at one end 46 thereof. The first link 30 is connected to the first jaw 18 and to the drive yoke 42. The first link 30 is pivotally connected to the first jaw 18 at the first pivot point 32. The first link 30 is pivotally connected to the drive yoke 42 at the second pivot point 34. The first link 30 is positioned between the first jaw 18 and the drive yoke 42. The second link (not shown) is in an identical arrangement with the second jaw (not shown) and the drive yoke 42.

An actuator means 52 is interconnected to the first jaw 18, to the second jaw 24 and to the drive yoke 42 so as to move the tubular-contacting surfaces 20, 26 and 44 radially inwardly and simultaneously for an identical distance. The drive yoke 42 is generally an elongated longitudinal member extending toward the tubular 1. An elastomeric pad is located on the end 46 of the drive yoke 42 as the tubular-contacting surface 44. The present invention contemplates that the pipe-contacting surfaces 20, 26, and 44 can be an elastomeric pad of a gripper, a toothed die of a tong, or a roller of a spinner.

Referring to FIG. 3, there is shown an upper perspective view of the tubular gripping apparatus 10 in the first position. Here, it can be seen that first jaw 18 has a first housing pivot 33. Second jaw 24 has a second housing pivot 39. The first and second housing pivots 33 and 39 allow the respective first and second jaws 18 and 24 to move toward or away from tubular 1 by pivoting about the housing pivots 33 and 39 relative to housing 56. In the first position, the jaws 18 and 24 are spread apart so as to release a tubular. That is, the jaws 18 and 24 of the jaw assembly 12 are open. When the jaws 18 and 24, along with the drive yoke 42, move toward the tubular 1, each of the

tubular-contacting surfaces 20, 26 and 44 will contact the outer surface of the tubular 1 simultaneously. As such, the actuator means 52 provides for the coordinated movement of the jaws 18 and 24 and the drive yoke 42. Each of the tubular-contacting surfaces 20, 26 and 44 moves radially inwardly simultaneously for an identical distance.

The actuator means 52 has a piston-and-cylinder assembly 54. The piston-and-cylinder assembly 54 has a piston connected to the drive yoke 42 so as to move the drive yoke 42 in a direction toward the tubular 1 or in a direction away from the tubular 1. The piston-and-cylinder assembly 54 is a conventional hydraulic actuator. It can be seen that a hydraulic line 114 is connected to the piston-and-cylinder assembly 54 so as to deliver hydraulic fluid for the actuator means 52 of the tubular gripping mechanism 10 of the present invention.

The first link 30 has a pivot point 32 at an end opposite pivot point 34. Likewise, the second link 36 has a pivot point 38 at an end opposite pivot point 40. As the drive yoke 42 moves toward the tubular 1, the links 30 and 36 cause the respective jaws 18 and 24 to rotate the pipe-contacting surfaces 20 and 26 inwardly toward the outer surface of tubular 1. If the diameter of tubular 1 is smaller, then the drive yoke 42 will move further toward the tubular 1 so as to cause the jaws 18 and 24 to rotate further inwardly. The movement of the drive yoke 42 causes the tubular-contacting surface 44 to contact the outer surface of tubular 1.

In using the tubular gripping mechanism of prior art, it was found that the clamping force exerted by the piston-and-cylinder assembly was continuous and would cause early wear, fatigue, and even failure in the gripping abilities of the prior art gripping apparatus. To alleviate this problem, the mechanism 10 of the present invention redirects the force of clamping away from the actuator means 52 (i.e. the piston-and-cylinder assembly 54) so that the assembly 54 does not continuously bear the load of gripping a tubular 1. The redirection of the force of clamping is accomplished by the locking means 58 of the mechanism 10 of the present invention. Another feature of the mechanism 10 of the present invention is that, in the construction of the tubular gripping mechanism 10 of the present invention, it is very important that if there is a failure in the piston-and-cylinder assembly 54 of actuator means 52, a failure in hydraulic power, or another sort of failure, that the tubular 1 remains firmly gripped by the jaws 18 and 24 of the jaw assembly 12 and the drive yoke 42. In the event of such a failure, the present invention is equipped with a locking means 58 which serves to prevent the unintended outward movement of the tubular-contacting surfaces 20, 26 and 44.

Referring still to FIG. 3, the drive yoke 42 has bearing bars 48 on a top thereof. A locking means 58 is positioned adjacent the bearing bars 48. The locking means 58 of the present invention includes a cylinder yoke 60 and a wedge assembly 68. The locking means 58 is interconnected to the drive yoke 42 so as to direct a load away from the actuator means 52 while the first and second jaws 18 and 24 of the jaw assembly 12 are in the second position. The cylinder yoke 60 is positioned around the piston-and cylinder assembly 54. The wedge assembly 68 is positioned adjacent the bearing bars 48. The wedge assembly 68 is also positioned adjacent the cylinder yoke 60. The wedge assembly 68 is suitable for contacting the cylinder yoke 60 so as to prevent a movement of the cylinder yoke 60. More particularly, the wedge assembly 68 contacts the cylinder yoke 60 so that the cylinder yoke 60 does not move backwards away from the drive yoke 42. The housing 56 is connected to the actuator means 52 and to the locking means 58. As a result of the construction of the locking means 58, if there is a failure in the hydraulics asso-

11

ciated with the piston-and-cylinder assembly 54, or any other problem affecting the integrity of tubular gripping mechanism 10, the wedge assembly 68 will bear against the bearing bars 48 so as to cause the surfaces of the wedges of the wedge assembly 68 to engage and stop any backward movement of the cylinder yoke 60. As a result, the tubular-contacting surfaces 20, 26 and 44 will remain properly urged against the outer surface of tubular 1.

A novel aspect of the apparatus 10 of the present invention is that a variety of tubular diameters can be utilized without the need to change the jaws 18 and 24 of the gripping apparatus 10. The present invention automatically grips different diameters of pipe while, at the same time, assuring a centering of such pipes with minimal error. The jaws 18 and 24 have two important measurements, R1 and R2. R1 is the distance between housing pivots 33 and 39 and the pipe-contacting surfaces 20 and 26 of the first and second jaws 18 and 24, respectively. R2 is the distance between the first pivot points 32 and 38 of the first and second links 30 and 36, and the housing pivots 33 and 39 of the first and second jaws 18 and 24, respectively.

In the mechanism 10, distance R1 is not equal to R2. Prior art is limited in that it requires R1 to equal R2. For example, the prior art gripping mechanism of U.S. Pat. No. 7,121,166 B2 has R1 equal to R2. Having R1 not equal to R2 in the present invention allows the present invention to grip different diameters of tubulars while simultaneously centering with minimal error. Any number of customized variations of tubular diameter ranges can be accommodated by geometrically solving for the optimum size of links 30 and 36 and appropriately sizing the distances R1 and R2 of the jaws 18 and 24 so as to provide the best mechanical advantage for the space available. Sizing the mechanism 10 of the present invention in this manner allows the mechanism 10 to grip with zero centering error for any two tubular reference diameters and nearly zero error for any tubular diameter between the reference diameters and just less than the smaller reference diameter and just more than the larger reference diameter. The prior art gripping apparatus of U.S. Pat. No. 7,121,166 B2 has zero error at only one pipe diameter, whereas the mechanism 10 of the present invention achieves zero centering error for any two tubular diameters. The present invention contemplates that any range of diameters would have a large diameter that is several times the value of the small diameter, and wherein this range of tubular diameters would have exactly zero centering error for at least two specific sizes of pipe. The present invention also is unlimited in the geometry relative to the distances R1 and R2. That is, R1 and R2 can be any values where R1 is not equal to R2.

Another important and novel feature of the present invention is the orientation of the links 30 and 36. First link 30 is pivotally connected to the drive yoke 42 at second pivot point 34. Link 30 angles outwardly to first pivot point 32, where the first link 30 is pivotally connected to the first jaw 18. Likewise, the second link 36 is pivotally connected to the drive yoke 42 at second pivot point 40 and angles outwardly to first pivot point 38, where the second link 36 is pivotally connected to the second jaw 24. The outward angle of links 30 and 36 uses less space than prior art gripping apparatuses that have links extending parallel to the length of the gripper. Thus, the mechanism 10 used in the method of the present invention can be used in smaller spaces than prior art gripping apparatus. The links 30 and 36 move both laterally and longitudinally, as opposed to only longitudinally.

When it is desired to release the tubular 1, it is only necessary for the piston-and-cylinder assembly 54 of actuator means 52 to move rearwardly. This serves to cause the tubu-

12

lar-contacting surfaces 20, 26 and 44 of the first jaw 18, second jaw 24, and drive yoke 42, respectively, to move radially outwardly away from the outer surface of the tubular 1 so as to properly release the tubular 1 in a desired location. Further movement of the piston-and-cylinder assembly 54 of the actuator means 52 rearwardly of the mechanism 10 will cause the jaws 18 and 24, along with the drive yoke 42, to move the tubular-contacting surfaces 20, 26 and 44 further away from each other so that this opening will allow the introduction of another tubular 1. Through the use of the present invention, a variety of tubular diameters can be utilized without the need to change the gripping mechanism 10. The mechanism 10 of the present invention automatically grips different diameters of tubular while, at the same time, assuring a proper centering of such tubulars. The size of the links 30 and 36, along with the relationship between the respective pivot points 32, 34, 38, and 40, is engineered so as to assure such simultaneous movement.

Referring to FIG. 4, there is shown an isolated perspective view of the locking means 58 of the mechanism 10 used in the preferred method of present invention. The locking means 58 has a cylinder yoke 60 and a wedge assembly 68. As FIG. 4 shows, a second locking assembly 110 can be included in the mechanism 10 of the present invention. In the event a second locking assembly 110 is included, a second set of bearing bars 112 would be positioned on the bottom of the drive yoke 42. The locking means 58 has a pair of clamping wedges 70 positioned adjacent bearing bars 48. Each of the clamping wedges 70 has a trapezoidal shape. The cylinder yoke 60 has a nose 62 on an end thereof adjacent the drive yoke 42. A braking plate 72 has an end 74 adjacent the clamping wedges 70. The braking plate 72 has an indentation 76 form in the end 74 thereof. The nose 62 of the cylinder yoke 60 is positioned in the indentation 76 when the mechanism 10 is in the first position. The locking means 58 in FIG. 4 is thus in the first position. A first braking wedge 82 is positioned adjacent a side 78 of the braking plate 72. A second braking wedge 86 is positioned adjacent an opposite side 80 of the braking plate 72. A first brake pad 90 is positioned adjacent a side 84 of the braking wedge 82 opposite the braking plate 72. A second brake pad 94 is positioned adjacent a side 88 of the braking wedge 86 opposite the braking plate 72. A first brake shoe 98 is positioned adjacent a side 92 of the first brake pad 90 opposite the first braking wedge 82. A second brake shoe 100 is positioned adjacent a side 96 of the second brake pad 94 opposite the second braking wedge 86. A first spring 102 is connected to one of the clamping wedges 70 and to the first brake pad 90. A second spring 104 is connected to the other of the pair of clamping wedges 70 and to the second brake pad 94. A third spring 106 is connected to the first braking wedge 82 and to the housing 56. A fourth spring 108 is connected to the braking plate 72 and to the housing 56.

The nose 62 of the cylinder yoke 60 has a detent 64. The detent 64 extends within the indentation 76 of the braking plate 72 when the locking means 58 is in the first position. The detent 64 is positioned adjacent a side of the clamping wedges 70 when the locking means 58 is in the second position, as is described hereinbelow. The first spring 102 is suitable for urging one of the clamping wedges 70 toward the other of the clamping wedges 70. The second spring 104 is suitable for urging the other of the clamping wedges 70 toward the one of the clamping wedges 70. The third spring 106 is suitable for urging the first braking wedge 82 toward the drive yoke 42. The fourth spring 108 is suitable for urging the braking plate 72 toward the drive yoke 42. The pair of clamping wedges 70 and the braking plate 72 and the first and second braking

wedges **82** and **86** and the first and second brake pads **90** and **94** and the first and second brake shoes **98** and **100** are all coplanar.

The clamping wedges **70**, braking plate **72**, and braking wedges **82** and **86** freely float above the cylinder yoke **60**. The braking plate **72** is positioned adjacent other wedges, but is only connected to the fourth spring **108**. The fourth spring **108** is in compression between the housing **56** and the braking plate **72**. Thus, the fourth spring **108** urges the braking plate **72** toward the drive yoke **42**. The first braking wedge **82** is positioned adjacent the braking plate **72** and the brake pad **90**, but is only connected to the third spring **106**. The third spring **106** is in compression between the housing **56** and the first braking wedge **82**. Thus, the third spring **106** urges the first braking wedge **82** toward the drive yoke. The clamping wedges **70** are freely positioned adjacent the braking plate **72** and the bearing bars **48**. The clamping wedges **70** are each connected to only a spring **102** and **104**. Spring **102** and **104** are in compression between the brake pads **90** and **94** and the clamping wedges **70**. As is described below, the wedges of the wedge assembly **68** move in response to a movement of the cylinder yoke **60**.

Referring to FIG. 5, there is shown an isolated perspective view of the cylinder yoke **60** positioned around the piston-and-cylinder assembly **54** of the actuator means **52**. The cylinder yoke **60** is attached to the piston of the piston-and-cylinder assembly **54**. The nose **62** of the cylinder yoke **60** has a detent **64**. The detent **64** provides a ledge that catches the clamping wedges **70** so as to prevent the cylinder yoke **60** from moving backwards away from a tubular **1** gripped by the mechanism **10**. When the detent **64** is engaged with the clamping wedges **70**, the load of gripping the tubular **1** is directed away from the piston-and-cylinder assembly **54** and into the clamping wedges **70** of the wedge assembly **68**. A portion **66** of the cylinder yoke extends through the interior of the drive yoke **42**. A protruding member **65** is attached to the piston of the piston-and-cylinder assembly **54**. The protruding member **65** engages with the drive yoke **42** so as to push the drive yoke **42** forward and backward, which in turn opens and closes the jaws **18** and **24** of the jaw assembly **12**. If a second locking assembly **110** is located on the bottom of the mechanism **10**, as discussed as an optional feature in FIG. 4, the cylinder yoke **60** can have a second nose with a detent formed on the bottom of the cylinder yoke **60**. The detent of the second nose would engage the wedge assembly of the second locking assembly in the same manner as described above for the nose **62** and wedge assembly **68**. The piston-and-cylinder assembly **54** of the actuator means **52** can be hydraulically actuated.

Referring to FIG. 6, there is shown a plan view of the locking means **58** of the mechanism **10** in the first position. In the first position, the piston of the actuator means **52** is retracted so as to position the cylinder yoke **60** and the wedge assembly **68** of the locking means **58** over the actuator means **52**. The drive yoke **42** has outwardly extending surfaces **43** and **45**, which are shown as dashed lines in FIGS. 6-9. In the first position, the load on the actuator means **52** is minimal and the wedge assembly **68** receives little of the load. Spring **102** urges one of the pair clamping wedges **70** against the other of the pair of clamping wedge **70**. Spring **104** urges the other of the clamping wedges **70** against the one of the clamping wedges **70**. Thus, in the first position, the pair of clamping wedges **70** touches each other. The clamping wedges **70** are received in the indentation **76** of the braking plate **72**. More particularly, each of the clamping wedges **70** is adjacent an angled portion **75** of the indentation **76**, and a portion of each wedge **70** is in the rectangular portion **77** of the indentation

76. The angled portion **75** is tapered so as to match the taper of the clamping wedges **70**. Thus, as the braking plate **72** and wedges **70** move with the cylinder yoke **60**, the clamping wedges **70** slide accordingly along the angled portion **75** of the indentation **76**. The side **71** of each of the clamping wedges **70** is adjacent the bearing bars **48**. Sides **78** and **80** of the braking plate **72** are appropriately tapered so as to create a wedging action with the tapered sides of the first and second braking wedges **82** and **86**, respectively. The sides **78** and **80** of the braking plate **72** are tapered adjacent the end of the braking plate **72** opposite end **74** where the indentation **76** is formed. Spring **108** urges the angled portion **75** of the braking plate **72** toward the clamping wedges **70**. Spring **106** urges the first braking wedge **82** toward the drive yoke **42** so as to engage the tapered side **78** of the braking plate **72**. The nose **62** of the drive yoke **60** resides in rectangular portion **77** of the indentation **76**. The first and second brake pads **90** and **94** are stationary within the mechanism **10** and serve to distribute the wedging forces between the braking plate **72** and the first and second braking wedges **82** and **86** over a greater length. The brake pads **90** and **94** transmit any load forces to the brake shoes **98** and **100**.

Referring to FIG. 7, there is shown a plan view of the locking means **58** in an intermediate position between the first and second positions. The piston of the actuator means **52** extends further out of the cylinder. Thus, the cylinder yoke **60** is closer to the drive yoke **42**. The portion **66** of the cylinder yoke **60** is in the interior of the drive yoke **42**. The actuator means **52** has moved the cylinder yoke **60** forward relative to the braking plate **72**. Spring **108** urges the braking plate forward, but the space between the bearing bars **48** and the braking plate **72** has increased and the nose **62** of the cylinder yoke **60** is pushing the clamping wedges **70** outwardly so that they slide upwardly along the angled portion **75** of the indentation **76** of the braking plate **72**.

Referring to FIG. 8, there is shown a plan view of the locking means **58** in the second position. In the second position, the load of clamping the tubular **1** is directed away from the actuator means **52** and into the wedge assembly **68**. The clamping force between the tubular **1** and the tubular-contacting surface **44** of the drive yoke **42** is directed through the tubular-contacting surface **44** and into the drive yoke **42**. The bearing bars **48**, which are welded to the drive yoke **42**, transmit the clamping force to the clamping wedges **70**. The clamping wedges **70** transmit the force to the braking plate **72**. The braking plate **72** directs the force in a transverse direction into the first and second braking wedges **82** and **86**. The braking wedges **82** and **86** transmit the force to the first and second brake pads **90** and **94**, respectively. The first and second brake pads **90** and **94** transmit the force to the first and second brake shoes **98** and **100**, respectively. The brake shoes **98** and **100** are mounted within the housing **56** and absorb the clamping load that is channeled through the wedge assembly **68** of the locking means **58**. By channeling the clamping force/load through the locking means **58**, the force is directed away from the actuator means **52** and increases the useful life of the actuator means **52**. Moreover, the locking means **58** provides a safety mechanism in the event that hydraulic power is lost to the mechanism **10** so that the jaws **18** and **24** of the jaw assembly **12** do not swing open and drop an extremely heavy tubular **1**. The wedges of the wedge assembly **68** are coplanar and are kept from popping out of alignment by the top of the housing **56**. The detent **64** of the nose **62** of the cylinder yoke **60** keeps the clamping wedges **70** from moving inwardly in response to forces exerted by springs **102** and **104**. While the locking means **58** is locked,

15

i.e. in the second position, hydraulic power that was used to clamp the mechanism 10 around the tubular 1 can be used for other applications.

The locking means 58 is unique in that it works for any size tubular 1 that is gripped by the jaw assembly 12. That is, the locking means 58 has an infinitely variable brake position. The taper of the clamping wedges 70 and the braking plate 72 allows more clamping force to be transmitted by the actuator means 52 to the tubular 1 than would be allowed without the locking means 58 as part of the mechanism 10. The tubular-contacting surfaces 20, 26, and 44 can be used as a gripper, a tong, or a spinner. Appropriate surfaces can be substituted so as to accomplish a particular function of the surfaces 20, 26, and 44.

The brake shoes 98 and 100 have slots 99 and 101 formed therein, respectively. The slots 99 and 101 are formed in the brake shoes 98 and 100 so as to accommodate a rail extending therethrough for structural support of the tubular gripping mechanism 10. This is an optional feature of the design of the mechanism 10. If the mechanism 10 includes a second locking means, as discussed above, then another set of brake shoes would be positioned on the bottom of the mechanism 10.

The method of the present invention is for gripping and a tubular 1 with a tubular gripping mechanism 10. The preferred method includes the steps of moving the tubular gripping mechanism 10 adjacent the tubular 1, positioning a jaw assembly 12 of the tubular gripping mechanism 10 around the tubular 1, applying a force by an actuator 52 onto the jaw assembly 12 of the tubular gripping mechanism 10 such that the jaw assembly 12 moves so as to clamp onto the tubular 1, removing the force from the actuator 52 on the jaw assembly 12 such that the jaw assembly 12 remains clamped onto the tubular 1 with the clamping force directed away from the actuator 52, and rotating the tubular 1 about a longitudinal axis 2 thereof when the force of the actuator 52 is removed (shown by arrow 3 in FIG. 1).

The tubular gripping mechanism 10 further has a drive yoke 42 having a tubular-contacting surface 44 at an end 46 thereof where the drive yoke 42 is cooperative with the jaw assembly 12. The step of applying a force includes applying a force by the actuator 52 onto the drive yoke 42 so as to urge the drive yoke outwardly into contact with the tubular 1. The step of applying a force further includes driving the drive yoke 42 and moving the jaw assembly 12 such that the tubular-contacting surfaces 20 and 26 thereof move radially inwardly for a substantially identical distance.

The tubular gripping mechanism 10 has a locking mechanism 58 therein. The method further includes engaging the jaw assembly 12 with the locking mechanism 58 such that the clamping force is passed away from the actuator 52 to the locking mechanism 58.

The drive yoke 42 has a bearing bar 48 thereon. The locking mechanism 58 has a cylinder yoke 60 with a nose 62 positioned adjacent the drive yoke 42 and a wedge assembly 68 positioned adjacent the bearing bars 48. The step of removing a force includes contacting the wedge assembly 68 with the cylinder yoke 60 so as to fix a position of the cylinder yoke 60, passing the nose 62 of the cylinder yoke 60 through the wedge assembly 68, orienting the wedge assembly 68 so that the nose 62 of the cylinder yoke 60 is outside the wedge assembly 68, preventing the nose 62 of the cylinder yoke 60 from moving interior of the wedge assembly 68, and transmitting the load from the drive yoke 42 to the wedge assembly 68.

The actuator 52 is a piston-and-cylinder assembly 54 cooperative with the jaw assembly 12. The step of removing a force includes retracting the piston-and-cylinder assembly 54

16

away from the tubular 1 so that a force of clamping is directed away from the piston-and-cylinder assembly 54.

In the method, the wedge assembly 68 comprises a pair of clamping wedges 70 positioned adjacent the bearing bar 48 and the nose 62 of the cylinder yoke 60, a braking plate 72 having an end 74 adjacent the pair of clamping wedges 70, a first braking wedge 82 positioned adjacent a side 78 of the braking plate 72, a second braking wedge 86 positioned adjacent an opposite side 80 of the braking plate 72, a first brake pad 90 positioned adjacent a side 84 of the first braking wedge 82 opposite the braking plate 72, a second brake pad 94 positioned adjacent a side 88 of the second braking wedge 86 opposite the braking plate 72, a first brake shoe 98 positioned adjacent a side 92 of the first brake pad 90 opposite the first braking wedge 82, and a second brake shoe 100 positioned adjacent a side 96 of the second brake pad 94 opposite the second braking wedge 86.

The step of passing the nose 62 comprises traveling the nose 62 between the pair of clamping wedges 70 from the indentation 76 of the braking plate 72 to a side 71 of the pair of clamping wedges 70 (seen in FIGS. 6-8). The step of orienting the wedge assembly 68 comprises pushing the pair of clamping wedges 70 together, urging the braking plate 72 toward the drive yoke 42, and urging the first braking wedge 82 toward the drive yoke 42. The step of preventing the nose 62 comprises contacting the pair of clamping wedges 70 with a detent 64 formed in the nose 62.

The step of transmitting the load from the drive yoke 42 to the wedge assembly 68 includes passing the load from the bearing bar 48 of the drive yoke 42 to the pair of clamping wedges 70, passing the load from the pair of clamping wedges 70 to the braking plate 72, passing the load from the braking plate 72 to the first and second braking wedges 82 and 86, passing the load from the first and second braking wedges 82 and 86 to the first and second brake pads 90 and 94, and passing the load from the first and second brake pads 90 and 94 to the first and second brake shoes 98 and 100, respectively. The step of passing the load from the pair of clamping wedges 70 to the braking plate 72 comprises contacting the pair of clamping wedges 70 with an angled portion 75 of the indentation 76 of the braking plate 72. The step of passing the load from the braking plate 72 to the first and second braking wedges 82 and 86 comprises contacting the side 78 of the braking plate 72 with the first braking wedge 82, and contacting the opposite side 80 of the braking plate 72 with the second braking wedge 86. The step of passing the load from the first and second braking wedges 82 and 86 to the first and second brake pads 90 and 94 comprises contacting the first brake pad 90 with the side 84 of the first braking wedge 82, and contacting the second brake pad 94 with the side 88 of the second braking wedge 86. The step of passing the load from the first and second brake pads 90 and 94 to the first and second brake shoes 98 and 100 comprises contacting the first brake shoe 98 with the side 92 of the first brake pad 90, and contacting the second brake shoe 100 with the side 96 of the second brake pad 94.

The foregoing disclosure and description of the invention is illustrative and explanatory thereof. Various changes in the details of the illustrated construction can be made within the scope of the appended claims without departing from the true spirit of the invention. The present invention should only be limited by the following claims and their legal equivalents.

I claim:

1. A method for gripping a tubular comprising:
 - moving a tubular gripping mechanism adjacent the tubular, the tubular gripping mechanism having a drive yoke with a tubular-contacting surface at an end thereof;

17

positioning a jaw assembly of the tubular gripping mechanism around the tubular, the jaw assembly being cooperative with the drive yoke, and having a tubular-contacting surface at an end thereof;

applying a force by an actuator onto the jaw assembly of the tubular gripping mechanism such that the jaw assembly moves so as to clamp onto the tubular with a clamping force; and

removing the force from the actuator on the jaw assembly such that the jaw assembly remains clamped onto the tubular with the clamping force directed away from the actuator.

2. The method of claim 1, further comprising: rotating the tubular about a longitudinal axis thereof when the force of the actuator is removed.

3. The method of claim 1, the step of applying a force comprising: applying a force by the actuator onto the drive yoke so as to urge the drive yoke outwardly into contact with the tubular.

4. The method of claim 3, the step of applying a force further comprising: driving the drive yoke and moving the jaw assembly such that the tubular-contacting surfaces of the drive yoke and jaw assembly move radially inwardly for a substantially identical distance.

5. The method of claim 3, the tubular gripping mechanism having a locking mechanism therein, the method further comprising: engaging the drive yoke with the locking mechanism such that the clamping force is passed away from the actuator to the locking mechanism.

6. The method of claim 5, the drive yoke having a bearing bar thereon, the locking mechanism having a cylinder yoke with a nose positioned adjacent the drive yoke and a wedge assembly positioned adjacent the bearing bar, the step of removing a force comprising: contacting the wedge assembly with the cylinder yoke so as to fix a position of the cylinder yoke.

7. The method of claim 6, the step of removing a force further comprising: passing the nose of the cylinder yoke through the wedge assembly; orienting the wedge assembly so that the nose of the cylinder yoke is outside the wedge assembly; preventing the nose of the cylinder yoke from moving interior of the wedge assembly; and transmitting the load from the drive yoke to the wedge assembly.

8. The method of claim 7, the wedge assembly comprising: a pair of clamping wedges positioned adjacent the bearing bar, the pair of clamping wedges positioned adjacent the nose of the cylinder yoke; a braking plate having an end adjacent the pair of clamping wedges, the braking plate having an indentation formed in the end; a first braking wedge positioned adjacent a side of the braking plate; a second braking wedge positioned adjacent an opposite side of the braking plate; a first brake pad positioned adjacent a side of the first braking wedge opposite the braking plate; and a second brake pad positioned adjacent a side of the second braking wedge opposite the braking plate;

18

a first brake shoe positioned adjacent a side of the first brake pad opposite the first braking wedge; and a second brake shoe positioned adjacent a side of the second brake pad opposite the second braking wedge.

9. The method of claim 8, the step of passing the nose comprising: traveling the nose between the pair of clamping wedges from the indentation of the braking plate to a side of the pair of clamping wedges.

10. The method of claim 9, the step of orienting the wedge assembly comprising: pushing the pair of clamping wedges together; urging the braking plate toward the drive yoke; and urging the first braking wedge toward the drive yoke.

11. The method of claim 9, the step of preventing the nose comprising: contacting the pair of clamping wedges with a detent formed in the nose.

12. The method of claim 8, the step of transmitting the load from the drive yoke to the wedge assembly comprising: passing the load from the bearing bar of the drive yoke to the pair of clamping wedges; passing the load from the pair of clamping wedges to the braking plate; passing the load from the braking plate to the first and second braking wedges; passing the load from the first and second braking wedges to the first and second brake pads; and passing the load from the first and second brake pads to the first and second brake shoes.

13. The method of claim 12, the step of passing the load from the pair of clamping wedges to the braking plate comprising: contacting the pair of clamping wedges with an angled portion of the indentation of the braking plate.

14. The method of claim 12, the step of passing the load from the braking plate to the first and second braking wedges comprising: contacting the side of the braking plate with the first braking wedge; and contacting the opposite side of the braking plate with the second braking wedge.

15. The method of claim 12, the step of passing the load from the first and second braking wedges to the first and second brake pads comprising: contacting the first brake pad with the side of the first braking wedge; and contacting the second brake pad with the side of the second braking wedge.

16. The method of claim 12, the step of passing the load from the first and second brake pads to the first and second brake shoes comprising: contacting the first brake shoe with the side of the first brake pad; and contacting the second brake shoe with the side of the second brake pad.

17. The method of claim 1, the actuator being a piston-and-cylinder assembly cooperative with the jaw assembly, the step of removing a force comprising: retracting the piston-and-cylinder assembly away from the tubular so that a force of clamping is directed away from the piston-and-cylinder assembly.

* * * * *